



## Installation Guidelines

### Heated Underlayment for Laminated Flooring

Revolutionary ThermoFloor® laminate floor underlayment now combines the luxury of safe and soothing warmth with all the advantages of an upgraded underlayment for floating laminate and some floating hardwood flooring:

- There is no easier way to heat your floor than with ThermoFloor®.
- No metal heating wires provides safest heat possible for warm floors.
- Complements home heating system making rooms more comfortable.
- Allows for reducing the central heating thermostat & saves on heat bills.
- An upgrade to poly foam underlayments for floating floors.
- Smooths out minor subfloor imperfections.
- Quiets impact sound and floor to ceiling noise.
- Dampens ambient sound in the room it's installed in.
- Inhibits sound from traveling to the room below.
- Certified field sound tests performed over a standard concrete subfloor received an FIIC score of "60".
- Moisture absorbing synthetic fibers wick moisture away from laminate floors.
- Increases R-value to help insulate subfloors.
- Made with ThermoSoft®FiberThermics®Heating Elements. US Patent # US 6,563,094 B2



ThermoFloor® is available in 120 Volt and 240 Volt in the following sizes:

Volts	Model	Dimensions	Sq. Ft.	Watts	Amps
120	TF1504-120	1.5' x 4'	6	47	0.4
120	TF1505-120	1.5' x 5'	7.5	59	0.5
120	TF1506-120	1.5' x 6'	9	72	0.6
120	TF1508-120	1.5' x 8'	12	97	0.8
120	TF1510-120	1.5' x 10'	15	122	1
120	TF1512-120	1.5' x 12'	18	147	1.2
120	TF3002-120	3' x 2'	6	48	0.4
120	TF3003-120	3' x 3'	9	76	0.6
120	TF3004-120	3' x 4'	12	103	0.9
120	TF3005-120	3' x 5'	15	131	1.1
120	TF3006-120	3' x 6'	18	158	1.3
120	TF3008-120	3' x 8'	24	215	1.7
120	TF3010-120	3' x 10'	30	269	2.2
120	TF3012-120	3' x 12'	36	323	2.7
240	TF1508-240	1.5' x 8'	12	97	0.4
240	TF1510-240	1.5' x 10'	15	122	0.5
240	TF1511-240	1.5' x 11'	16.5	134	0.6
240	TF1512-240	1.5' x 12'	18	147	0.6
240	TF1514-240	1.5' x 14'	21	172	0.7
240	TF1516-240	1.5' x 16'	24	197	0.8
240	TF1518-240	1.5' x 18'	27	216	0.9
240	TF1520-240	1.5' x 20'	30	247	1
240	TF1524-240	1.5' x 24'	36	297	1.2
240	TF3004-240	3' x 4'	12	103	0.4
240	TF3005-240	3' x 5'	15	131	0.6
240	TF3006-240	3' x 6'	18	158	0.7
240	TF3008-240	3' x 8'	24	213	0.9
240	TF3010-240	3' x 10'	30	268	1.1
240	TF3012-240	3' x 12'	36	323	1.4
240	TF3014-240	3' x 14'	42	378	1.6
240	TF3016-240	3' x 16'	48	433	1.8
240	TF3018-240	3' x 18'	54	432	1.8
240	TF3020-240	3' x 20'	60	543	2.3
240	TF3024-240	3' x 24'	72	653	2.7



Conforms to UL  
Safety Standard  
1693



Made with  
Recycled  
Materials



\*\*To use ThermoFloor as the sole room heating source, make sure your BTU requirements are met by the total Watts of ThermoFloor installed. 1,000 Watts = 3,412 BTU's/hour.



### **CAUTIONS:**

THIS EQUIPMENT SHALL BE INSTALLED ONLY BY QUALIFIED PERSONNEL WHO ARE FAMILIAR WITH THE CONSTRUCTION AND OPERATION OF THE APPARATUS AND THE RISKS INVOLVED.

THE INSTALLATION OF THIS HEATING PRODUCT SHALL BE IN ACCORDANCE WITH THE MANUFACTURER'S INSTRUCTIONS AND LOCAL AND NATIONAL CODES.

IN CANADA, THE INSTALLATION SHALL BE MADE ACCORDING TO THE PROVISIONS OF SECTION 62 OF THE CANADIAN ELECTRICAL CODE, PART 1.

WARNING - AS DESCRIBED IN THESE INSTRUCTIONS, LEAD WIRES ARE NOT TO BE ROUTED OVER PADS OR COME INTO CONTACT WITH THE HEATING ELEMENTS AS DAMAGE TO SUPPLY CONDUCTOR INSULATION MAY OCCUR IF CONDUCTORS ARE ROUTED TO CONTACT HEATING ELEMENTS. REFER TO INSTALLATION INSTRUCTIONS FOR RECOMMENDED MEANS OF ROUTING SUPPLY CONDUCTORS. THE TYPE AND THICKNESS OF FLOOR COVERING MATERIALS USED WITH THIS PRODUCT MUST NOT EXCEED A THERMAL INSULATION "R" VALUE OF 2.0.

CAUTION: USE COPPER ONLY AS SUPPLY CONDUCTORS.

THERE ARE NO SPECIAL CRIMPING TOOLS REQUIRED FOR THIS PRODUCT.

ATTENTION: CONIFIER L'INSTALLATION DE CE MATERIEL AUN PERSONNEL QUALIFIE, QUI CONNAIT BIEN L'APPAREIL ET LES RISQUES INHERENTS.

CE SYSTEME DE PANNEAUX CHAUFFANTE DOIT ETRE INSTALLECONFORMEMENT AUX EXIGENCES DE TOUS LES POUVOIRS DE REGLEMENTATION.

ATTENTION: UTILISER DES CONDUCTEURS EN CUIVRE SEULEMENT.

### **OVERVIEW:**

ThermoFloor® may be used in these types of flooring applications:

1. Floating laminate and floating wood floors.\*
2. Glued-down engineered and solid wood floors.\*
3. Ceramic and porcelain tile floors.\*
4. Carpet or vinyl tile and WTW carpet with a fiberboard layer above ThermoFloor (see section 4). Do not install ThermoFloor under marble, travertine, slate or natural stone.

Do not install ThermoFloor in walls.

For Installations not covered in these directions, consult customer service before installation. Installations not performed within the stated manner may void all warranties.

\* Refer to Floor Covering Manufacturer's specifications for compatibility of their product over radiant heat before installation.

Each of the above applications requires 5 basic steps:

- A. Electrical Rough-In
- B. Planning & Preparation
- C. ThermoFloor Installation
- D. Floor Covering Installation

## 1. FLOATING HARD SURFACE FLOORS (including laminate, wood and interlocking tile)

### 1-A Electrical Rough-In

#### Install GFCI Breaker – (Over-current Protection)

1. ThermoFloor® must be installed with a ground fault circuit interrupter (GFCI). We recommend installing ThermoFloor with our programmable thermostat (purchased separately) with a built-in GFCI. If you are not using a thermostat with GFCI already built-in, then install a dedicated, indicating-type GFCI. This GFCI serves as a local disconnect.
  - Note: Follow all local building and electrical codes.
  - It is possible to branch from an existing circuit if the Amps provided by the circuit are sufficient to supply the Amp load of the floor heating mats and all other appliances that are or will be connected to the circuit. If the Amp supply is not sufficient, install a dedicated circuit.
  - Consult with a qualified electrician to determine if the circuit can handle the load and if the circuit is GFCI-protected. The size of the breaker is determined by the total Amp load of the heated padding. You may need multiple breakers, multiple thermostats or a contactor/relay for systems larger than 15 Amps.

#### Install Electrical Boxes

2. Thermostats are usually located near the power leads. However, they can be located almost anywhere, because the power leads and the sensor wire can be routed to electrical junction boxes and extended to a location outside the heated room (such as a utility room).
3. For the programmable thermostat, install a 1-gang (2" wide) or 2-gang (4" wide) electrical box with a 1-gang mud ring.  
(Note: the 4" box provides more room to work with multiple lead wires). Using our manual thermostat, install a 2.25" wide or 4" electric box. Electrical boxes are typically located 4'-5' from the floor.
4. The floor sensor wire can be extended up to 50' (maximum) if necessary.

#### Bottom Plate Work

5. Drill or saw holes at the bottom plate (See Fig 1.) One hole is for routing the power leads and the other hole is for routing the thermostat sensor wire. These holes should be directly below the electrical box(es).
6. Power lead conduit: remove one of the knock-outs in the electrical box to install conduit for leads.
7. Install 1/2" minimum conduit from the bottom plate up to the electrical box. Install 3/4" conduit if necessary to make room for more lead wires when using multiple ThermoFloor heated underlayment pads. (See Fig 1.) Close one end of conduit to junction box enclosure with appropriate fitting/locknut. Close bottom end of the conduit flush with the wall and fit with insulated bushings to prevent chafing of wire on exposed edge.
8. The thermostat (purchased separately) comes with a floor sensor. The floor sensor can be installed in a conduit separate from the power lead wire conduit although installation of the sensor in conduit is not necessary. Check the resistance of the sensor wire to be sure it is near 14.8 kOhms at 68° F. Suggestion: install a 3/8" plastic or copper tube from the electric box going down the wall and under the floor for sliding the sensor wire in and out should it ever become necessary to replace the sensor. Close the end of the tube under the floor.
9. Open a second knock-out in the bottom of the thermostat box. Feed the sensor through the knock-out down through the cut-out in the bottom plate, and out into the floor area where the ThermoFloor heated underlayment will be installed.

#### Rough-in Wiring

11. Install appropriate electrical wire (conductor) from the power source and GFCI protection to the thermostat following all codes. Leave extra wire at the thermostat box for making connections. Refer to the Typical Wiring Diagrams (Fig.4 on page 6) for help.

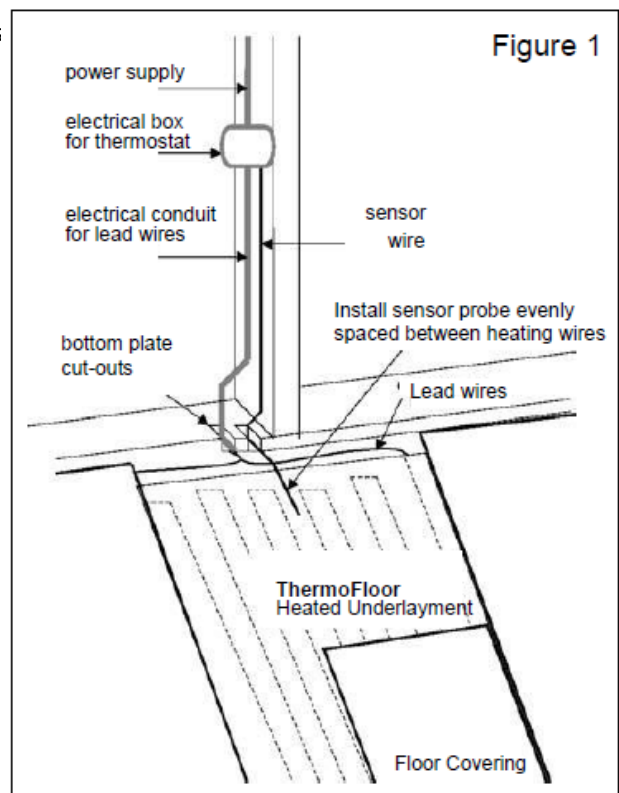

## Installing a Relay (Contactor)

12. Depending on the Amp requirements of multiple ThermoFloor® heated underlayment pads, a relay may be required. Consult with an electrician to determine the type and size of relay required.

### 1-B Planning & Preparation

1. Plan the heated area of the floor so that the desired traffic areas can be heated with a combination of the available mat sizes. When planning your heated floor area, keep the following important points in mind:
  - Non-heated areas of the floor must be covered with unheated underlayment that can be cut to fit the areas of the floor that cannot be covered by ThermoFloor heated underlayment. This will keep your floor level.
  - Do not cut ThermoFloor heated underlayment or cut or pierce ThermoFloor's heating wires.
  - Do not overlap ThermoFloor heated underlayment.
  - Do not duct tape over ThermoFloor's heating wires.
  - Do not power 120V mats with 240 Volt power. Power 120V mats with 120V power and 240V mats with 240V power.
  - Lead wires should run along the end of the mats to the nearest wall and electrical junction box. Check local and national codes regarding the use of conduit from the floor to the junction box. A licensed electrician must make all electrical connections.
  - Do not run lead wires over or under mats.
  - Do not install ThermoFloor heaters under cabinets, built-ins or furniture with a solid surface base. Excessive heat will accumulate under these items and may damage ThermoFloor's heating elements.
2. With all approved floor types, be sure the subfloor surface is clean and dry\*. The floor must be completely swept of all debris including all nails, dirt, wood and other construction debris. Make absolutely sure there are no objects on the floor that might damage the ThermoFloor wires.

\*Where concrete slabs are subject to excessive moisture, a calcium chloride moisture test is recommended. Vapor emission readings in excess of 3 lbs. per 1,000 square feet in 24 hours may require additional protection such as a concrete sealant or 6 mil (.006") polyethylene sheeting (vapor barrier).

3. Before starting, remove the ThermoFloor heated underlayment from the box. Attach both lead wires (120V: black & white; 240V: black & red) to a high-quality digital ohmmeter to measure the resistance. Compare the resistance you measured to the resistance recorded by the factory on the label attached to the padding. If the resistance is not within  $\pm 10\%$  of the factory recorded resistance, call our customer service number for assistance. Damage may have occurred during shipping. Do not proceed with the installation. Keep a record of resistance measures as they will be needed for warranty purposes.
4. Leave the factory labels attached to the padding and the lead wires for later inspection. Save warning label #1 and place it inside the breaker panel to identify the radiant flooring circuit.

### 1-C ThermoFloor® Installation



1. Lay ThermoFloor underlayment over the subfloor with the heating wires facing up. (Photo 1)
2. Layout lead wires so they run to the nearest wall with an electrical box. (See Fig. 2 page 5.) Connections will be made later. (Photo 2)
3. Allow approximately 1" of floor space between the wall and ThermoFloor to run the lead wires to the conduit. Use strips of duct tape to hold lead wires in place – DO NOT STAPLE.
4. Padding should be completely flat, butted together flush, do not overlap the pad.
5. Tape the seams with duct tape or other water and tear resistant, utility-grade, poly-coated cloth backed tape that has a very aggressive adhesive. (Photo 3)

#### **Do not tape over ThermoFloor's heating wires.**

6. The thermostat sensor wire should be installed on top of the ThermoFloor heated underlayment and routed up the wall to the thermostat electrical box. Place the tip of the sensor wire evenly spaced between two ThermoFloor heating wires extending about 6"-12" into the ThermoFloor heated underlayment. (Refer to Fig. 3 Sensor Wire Location on page 5.) It is acceptable to use a utility knife to notch out a 1/4" x 1" piece of the padding material to

imbed the sensor (DO NOT CUT THE HEATING WIRE). You can tape the sensor wire in place but do not tape over the sensor probe as this will cause heat to build up causing the thermostat to reduce power to ThermoFloor. Do not tape over ThermoFloor heating elements.

### 1-D Floor Covering Installation

1. When installing the floor, be careful not to damage ThermoFloor's heating elements. If the floor covering is not immediately installed, protect ThermoFloor heated underlayment with corrugated box material or plywood.
  - Keep traffic to a minimum on installed ThermoFloor heated underlayment prior to floor covering installation.
  - Avoid dropping, rolling or dragging objects or tools over the heating elements.
  - Be careful that nails, screws or other fasteners do not penetrate the floor in the area of ThermoFloor. ThermoFloor's heating elements can be damaged by fasteners penetrating the floor.
2. Install the floating laminate or floating wood floor as per manufacturer's instructions.

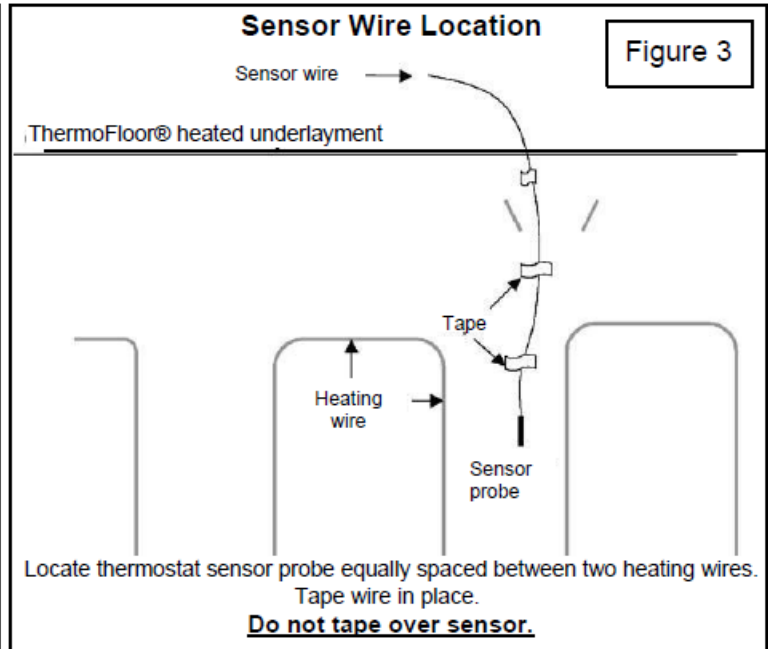
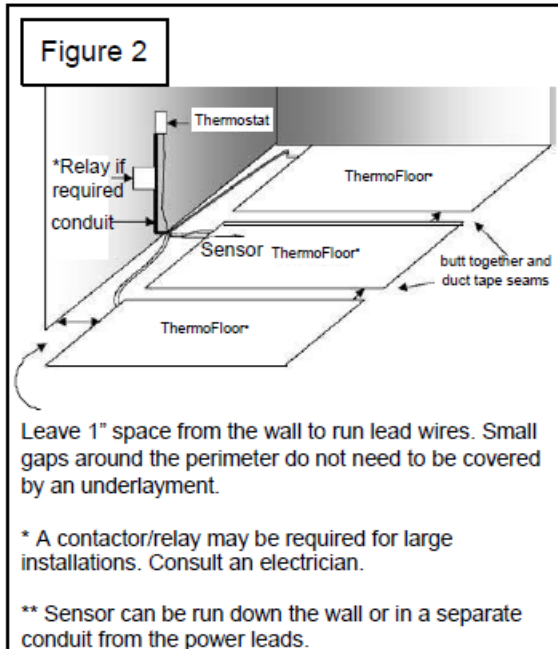

### 1-E Final Wiring & Connections

1. After installing your floor, use the ohmmeter to record the final resistance measurement of the ThermoFloor heated underlayment. The resistance must be within  $\pm 10\%$  of the factory recorded resistance. If not, call our customer service number for assistance. Damage may have occurred during floor installation. Keep a record of all three resistance measures as they will be needed for warranty purposes. See Resistance Measures Chart, page 9.
2. Install the floor sensing thermostat in the 4" square electrical box according to the installation instructions provided with the thermostat. Connect the power mat leads, floor sensor, and power supply wiring as shown in the thermostat instructions and as diagramed on the back of the thermostat. For wiring diagrams, see Figure 4, page 6.
3. Route ThermoFloor lead wires up through the electrical conduit and into the 4" square thermostat box. Wire the leads in parallel (not series) 120V: black-black (line) and white-white (neutral); 240V black-black (line) and red-red (line). Then wire a short "pig-tail" (of correctly sized wire for the load) over to the thermostat. The number of conductors per connection must not exceed the amperage rating of the circuit or local or national codes. Field wiring must be 14 gauge or as otherwise appropriate for the Amp load of the installation as specified by local and national codes.
4. Use a 1-gang mud ring to mount the thermostat if using a 4" electrical box.
5. Indicate which circuits supply the ThermoFloor heated underlayment and retain the ETL labels for each ThermoFloor pad in a convenient location, i.e., taped to the circuit breaker box, for reference by the electrical inspector or homeowner. Leave one ETL label attached to the ThermoFloor pad. Attached warning label #1 in a convenient location e.g., inside of breaker panel, or thermostat control door in the room where ThermoFloor is installed.
6. After all thermostatic controls are installed, power up the system to briefly test operation of all components.
7. Refer to instructions provided with the thermostatic controls for proper setting. Keep instructions in a safe place for future reference.

## 2. GLUED-DOWN ENGINEERED AND SOLID WOOD FLOORS

**2-A Electrical Rough-In:** See section 1-A.

**2-B Planning & Preparation:** See section 1-B.

**2-C ThermoFloor® Installation**

**Approved Surfaces for Applications:** Plywood, wood, hardboard underlayment, association grade particleboard, concrete above grade in the absence of excessive moisture and/or excessive alkali, and well-bonded VCT\* and sheet vinyl\* (non-embossed and non-cushioned). Sub-floor must meet NWFA (National Hardwood Flooring Association) and local building code standards for quality, thickness and maximum deflection.

**\*Sheet Vinyl or VCT:**

- If possible, remove the old sheet vinyl or VCT. It is almost always better to install over the original sub-floor surface.
- Wood sub-floors that are structurally suitable for vinyl, may not be suitable for ceramic tile or wood floors. Double-check the sub-floor requirements.
- If not removed, the vinyl must be well adhered to the sub-floor throughout the entire floor.
- If installing on top of vinyl, make sure the adhesive is approved for use on vinyl.
- Allow additional drying or “set” time (at least twice the manufacturer’s recommendation) for the setting material used in each phase of the installation.

**Figure 4**

### Thermostat Wiring Diagrams

\*\*\*Refer to Instructions that came with your specific thermostat\*\*\*

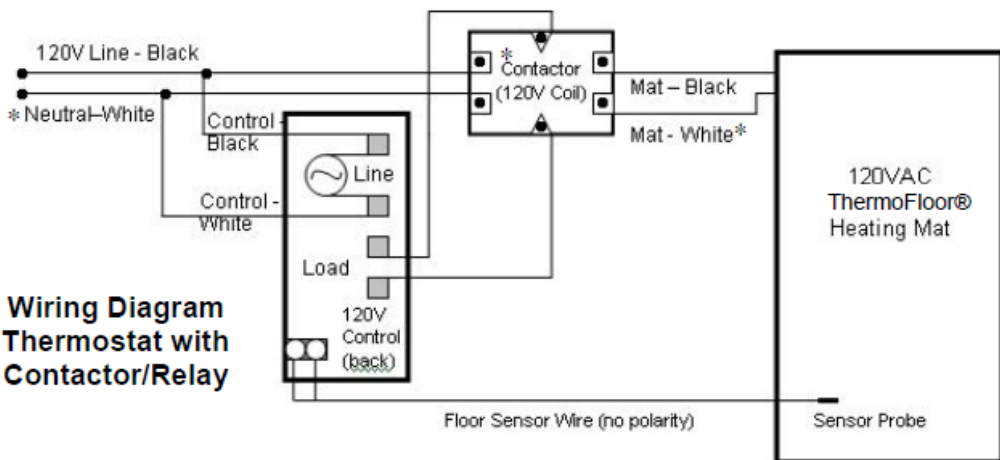
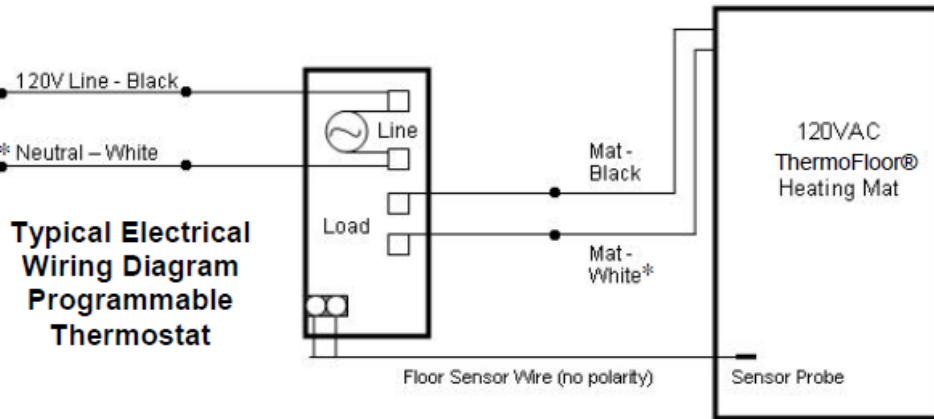

All electrical work must be done by a qualified, licensed electrician in accordance with local building and electrical codes, and the National Electrical Code (NEC), especially Article 424, Part IX of the NEC, ANSI/NFPA 70 and Section 62 of CEC Part I.

Note: if installing a programmable thermostat, do not install an external timer. The timer will disrupt the programming. If interfacing with a building energy management system, use a manual thermostat.

\* If installing 240V heating mats, the lead wires are black (line) and red (line) - not white (neutral). ThermoSoft's programmable thermostat accepts dual 120/240V input. Otherwise, make sure all components are rated 240V.

### Installation Methods:

#### Glued-Down Wood Method #2-1

**Setting Material:** Use only wood flooring adhesive approved by the flooring material manufacturer below and above the ThermoFloor®.

**Trowel Size:** 3/16" x 3/16" Square-notch or U-notch

#### Sub-floor Requirements:

- Maximum 1/4" variance in 10'.
- Must be properly prepared per NWFA specifications.
- All cracks in excess of 1/16" must be filled.
- Surface must be clean, dry and free of contaminants and sealers.

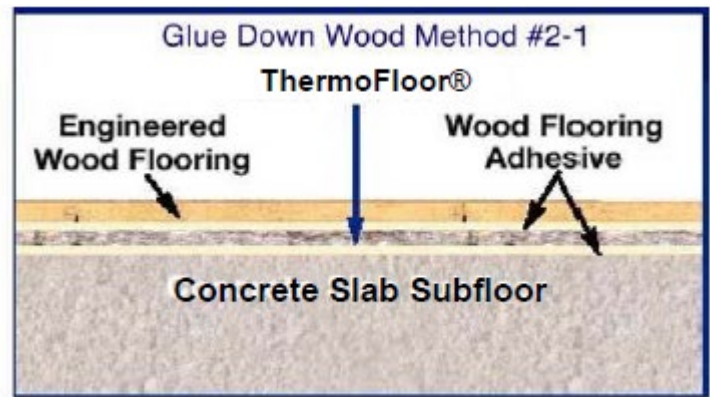

#### Installing ThermoFloor®

1. Lay out the ThermoFloor heated underlayment.
2. Except for approximately 1" of space between the walls and ThermoFloor® to run the lead wires, be sure to run ThermoFloor® to the edges of the perimeter leaving no gaps. Where necessary, use unheated underlayment padding to fill in the gaps. Duct tape all seams. Do not tape over heating wire.
3. Pull back the ThermoFloor heated underlayment.
4. Apply adhesive to the subfloor as per manufacturer's instructions.
5. Lay the ThermoFloor back into the adhesive.
6. Immediately (within 10 minutes) roll the ThermoFloor with a 35 lb roller in diagonal directions.
7. Do not walk on the rolled areas.
8. Seams should be butted together, leaving no gaps or overlaps.
9. Allow set time as per adhesive manufacturer's instructions.

#### Glued-Down Wood Method #2-2

**Setting Material:** (Same as Method #2-1)

**Trowel Size:** (Same as Method #2-1)

#### Sub-floor Requirements:

- Must comply with NWFA sub-floor requirements.
- Sub-floor must be structurally sound and free from contaminants and sealers.
- Minimum variation of 1/4" in 10', with a 16" on-center joists.

**Installing ThermoFloor®:** Same as Method #2-1.

**2-D Floor Covering Installation:** Install flooring material as per flooring manufacturers and NWFA recommendations.

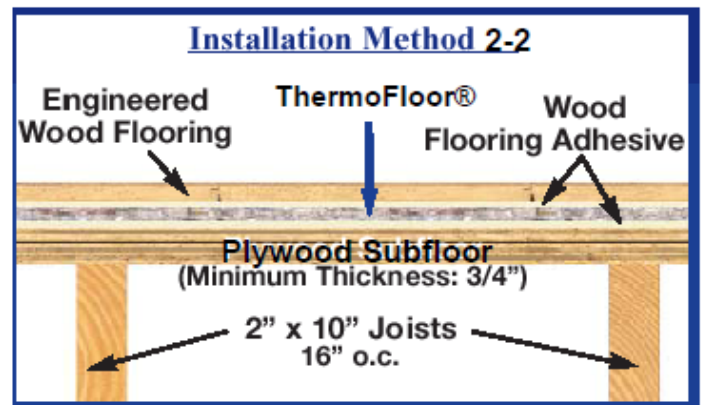

**2-E Final Wiring & Connections:** See section 1-E.

## 3. CERAMIC TILE & PORCELAIN TILE FLOORS

**3-A Electrical Rough-In:** See section 1-A.

**3-B Planning & Preparation:** See section 1-B.

#### 3-C ThermoFloor® Installation

ThermoFloor is approved for Type II tile applications. Do not use in shower pan applications or areas exposed to excessive moisture. Do not use under marble, travertine, slate or natural stone floors.

#### Conditioning:

The underlayment and adhesives must be conditioned at 70 degrees Fahrenheit with the relative humidity between 25 and 65% for at least 24 hrs before and 72 hrs after installation.

#### Approved Surfaces for Applications:

Exterior Glue or Exposure 1 Plywood, concrete backer board, concrete in the absence of excess moisture and/or excessive alkali, and well bonded VCT\* or sheet vinyl\* (non-embossed and non-cushioned). All sub-floor structures must meet or exceed the American National Standard Specifications (ANSI) standards for quality, thickness, and maximum deflection. The sub-floor must also comply with any local building code standards.

### Unsuitable substrates:

The following is a list of sub-floor surfaces NOT suitable for tile installations as published by The National Tile Contractors Association: masonite, all grades of lauan plywood, expanded polystyrene (styrofoam) insulation board, particle board, paneling, stripwood floors, grease-saturated concrete, sheathing and/or other oriented strand board, pressure-treated plywood, fire-resistant plywood, curing compounds, felt paper and scribing felt.

### \*Sheet Vinyl or VCT:

- If possible, remove the old sheet vinyl or VCT. It is almost always better to install over the original sub-floor surface.
- Wood sub-floors that are structurally suitable for vinyl, may not be suitable for ceramic tile or wood floors. Double-check the sub-floor requirements.
- If not removed, the vinyl must be well adhered to the sub-floor throughout the entire floor.
- If installing on top of vinyl, make sure the mortar or adhesive is approved for use on vinyl.
- Allow additional drying or "set" time (at least twice the manufacturer's recommendation) for the setting material used in each phase of the installation.

### Surface preparation:

Floor must be clean, smooth, dry and free of foreign matter that would interfere with a good bond. Fill all cracks and depressions with a suitable floor patch. If adhesive removal chemicals have been used, make sure the floor has been properly rinsed and all chemical residues are removed. All existing cracks in excess of 1/16 inch must be properly repaired in accordance with ANSI standards for ceramic installations.

### Moisture:

All sub-floor assemblies should be tested for moisture vapor emission rates by utilizing anhydrous calcium chloride test kits for concrete. Do not install flooring material when in excess of flooring manufacturer's recommendations for moisture vapor emissions.

### Installation Methods:

#### Ceramic & Porcelain Tile Method #3-1: Ceramic floor tile (8" or larger) on concrete sub-floor

#### Setting Materials:

- Use Latex Portland cement mortar that conforms to test requirements found in ANSI A118.4.
- Hydrate (mix with water) according to the bag recommendations.
- Use a slow mixer (300 rpm or less) or mix by hand.
- Allow mixture to sit undisturbed for 15 minutes, then lightly remix.
- Mix epoxy grout as per manufacturer's instructions.
- Use epoxy grout as per ANSI A-4.6.3

#### Trowel Size:

- ThermoFloor to sub-floor: 1/4"x1/4"x1/4" Square or "U" notch.
- Tile to ThermoFloor: Use a square or "U" notch trowel with notch size appropriate for the size and type of tile installed. Minimum 1/4"x3/8"x1/4".

#### Concrete Requirements:

- Maximum variation of 1/4" in 10'-0". Deflection is not to exceed 1/360 of span.
- All cracks in excess of 1/16" must be filled as per ANSI specifications.
- Surface must be clean, dry and free of contaminants and sealers.
- Lightweight concrete surfaces must comply with manufacturer's specifications for tile installations.

#### Installing ThermoFloor®

1. Lay out the ThermoFloor heated underlayment.
2. Except for approximately 1" of space between the walls and ThermoFloor to run the lead wires, be sure to run ThermoFloor to the edges of the perimeter leaving no gaps. Where necessary, use Insulayment™ underlayment padding to fill in the gaps. Insulayment™ (NOT ThermoFloor) can be cut to size using a sharp utility knife and a straight edge.
3. Pull back the ThermoFloor heated underlayment.
4. Dampen, but do not saturate, the concrete floor with a sponge or a mist sprayer.
5. Key the thin-set mortar into the sub-floor with the flat side of a 1/4"x1/4" square or "U" notch trowel and then comb it with the notched side using a left to right motion.

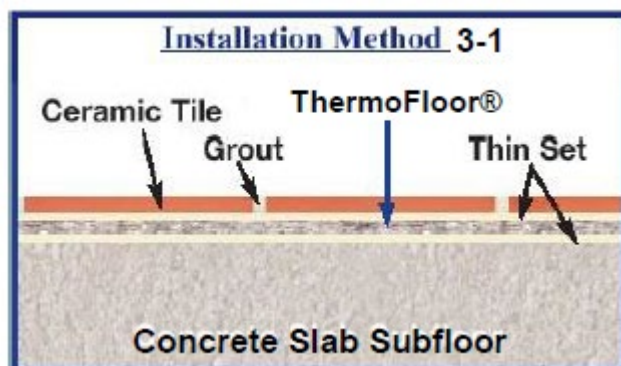



6. Apply the thin-set mortar only as far ahead as will allow installation of the ThermoFloor® prior to the mortar beginning to set or “skin over”.
7. Lay the ThermoFloor and lead wires back into the thin-set.
8. Immediately (within 10 minutes) roll the ThermoFloor with a 75lb roller in diagonal directions.
9. Do not walk on the rolled areas. Allowing traffic on the installed ThermoFloor prior to full set may cause indentations resulting in weak areas and hollow spots.
10. Make sure no trowel notch ridges remain under the ThermoFloor.
11. Seams should be butted together, leaving no gaps or overlaps.
12. Allow the ThermoFloor to set for at least 16 hrs.

### Ceramic and Porcelain Tile Method #3-2: Tile on Plywood Sub-floor

#### Setting Materials:

- For ThermoFloor to sub-floor: use EGP (Exterior Glue Plywood) Latex Portland Cement Mortar that conforms to ANSI A118.11.
- For Tile to ThermoFloor: use Latex Portland Cement Mortar that conforms to ANSI A118.4.
- **Use epoxy grout** as per ANSI A-4.6.3.

#### Trowel Size:

- ThermoFloor pad to sub-floor: 1/4" x 1/4" x 1/4" Square or “U” notch.
- Tile to ThermoFloor: Use a square or “U” notch trowel with notch size appropriate for the size and type of tile installed. Minimum 1/4"x3/8"x1/4".

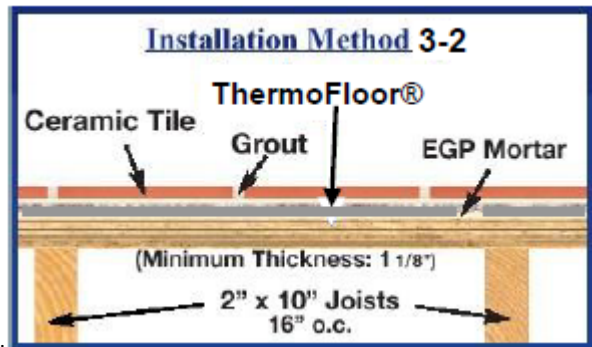

#### Sub-Floor Requirements:

- Sub-floor assembly must comply with ANSI A108.12.
- 16"oc, 2"x10" minimum joist: total sub-floor thickness - 1 1/8" with clean structurally sound exterior plywood as the top surface.
- 24"oc truss or I-joist: total sub-floor thickness - 1 1/2" with clean structurally sound exterior plywood as the top surface.
- Must be free of all sealers and contaminants.
- Maximum variation of 1/8" in 10'-0".
- Deflection is not to exceed 1/360 of span when measured under 300lb concentrated load (see ASTM C627).

#### Installing ThermoFloor® (Same as Installation Method #3-1)

##### Setting Tile:

1. Dampen, but do not saturate, the ThermoFloor® with a sponge or mist sprayer prior to thin-set application.
2. Use a square or “U” notch trowel size that is appropriate for the size of tile. (Minimum 1/4" x 3/8" x 1/4")
3. Use Latex Portland cement mortar that conforms to test requirements found in ANSI A118.4.
4. Key the thin-set into the ThermoFloor with the flat side of the trowel and then comb it with the notched side in the same direction as the ThermoFloor heating elements.
5. Press the tile into the thin-set using a front to back motion perpendicular to the spread of the thin-set for maximum transfer of the thin-set onto the tile.
6. Mortar average coverage per tile shall comply with ANSI A-108.5.3.3.3 which requires back-buttering each tile and 95% coverage with corners and edges fully supported.
7. Minimum grout joint width is 3/16".
8. **Allow no traffic on the tiled surface for at least 16hrs.**
9. Use **epoxy grout** and apply according to manufacturer’s instructions.

**3-E Final Wiring & Connections:** See section 1-E.

### Resistance Measure Chart\*

Factory Information (From ETL label)	Resistance Measure 1 (Out of the box)	Resistance Measure #2 (After laying ThermoFloor)	Resistance Measure #3 (After laying floor covering)
Serial number _____ Pad Size _____ Volts _____ Factory Resistance _____ Ohms	_____  (Ohms)	_____  (Ohms)	_____  (Ohms)
Serial number _____ Pad Size _____ Volts _____ Factory Resistance _____ Ohms	_____  (Ohms)	_____  (Ohms)	_____  (Ohms)
Serial number _____ Pad Size _____ Volts _____ Factory Resistance _____ Ohms	_____  (Ohms)	_____  (Ohms)	_____  (Ohms)
Serial number _____ Pad Size _____ Volts _____ Factory Resistance _____ Ohms	_____  (Ohms)	_____  (Ohms)	_____  (Ohms)

\*For each ThermoFloor®, use this convenient worksheet to record resistance measures. Retain this record for warranty purposes.

---

**Thermosoft International Corporation**  
**701 Corporate Woods Parkway • Vernon Hills, IL 60061**  
**Telephone 847-279-3800 • Facsimile 847-279-8845**  
**www.thermosoft.com**

## 4. CARPET & VINYL TILE. WALL-TO-WALL CARPET

**4-A Electrical Rough-In:** See section 1-A.

**4-B Planning & Preparation:** See section 1-B.

**4-C ThermoFloor® Installation:** See section 1-C.

**4-D Fiberboard layer installation.**

1. After laying ThermoFloor according to section 1-C, you will need to cover it with one layer of 4'x8'x1/8" fiberboard also known as medium density fiberboard (MDF) or hardboard. This will become a floating sub-floor that will not be fixed to the floor below.
2. The fiberboards must acclimate to the room where they will be installed for 48 hours at 65°F or more.
3. The floor heat system must be turned off during installation of fiberboards and final flooring.
4. Leave an expansion gap of 1/8"-1/4" between the fiberboards and all walls around the perimeter of the room and around pipes and other fixed objects. See note below 5. Leave an expansion gap of 1/8"-1/4" between all fiberboards.
6. Fiberboards can be cut by scoring 2-3 times along a straight edge with a utility knife and snapping along the cut line. This avoids creating dust that will impede bonding later.
7. **DO NOT CUT FIBERBOARDS OVER THE FLOOR HEATING SYSTEM** as you risk cutting the heating wires.
8. If installing carpet or vinyl tile, the fiberboard must be laid in a diagonal 45° pattern (see Diagram A) as follows (this step is not necessary for wall-to-wall carpet):
  - a. Cut one sheet in half to 4'x4'.
  - b. Cut one 4'x4' sheet in half diagonally so that it makes a triangle with 4' on two sides.
  - c. The pieces cut in a. and b. above will be laid in one corner of the room so that the longest sides of each triangle face the wall (see Diagram A pieces marked [1] and [2]).
  - d. Repeat the process in a. and b. of cutting 4'x4' triangular pieces as necessary to start each new row (see Diagram A pieces marked [5], [7], [9], [15] and [16]).
  - e. Lay fiberboard in sequence as numbered in the diagram so that the triangular pieces are laid first.
  - f. Be sure to maintain expansion gaps between fiberboards and fiberboard and walls as noted in steps 4 and 5 above.
  - g. Use cut pieces and trim as required to fill in remaining areas (see shaded areas in Diagram A).
  9. Duct tape the seams of the fiberboards to hold them in position while laying the flooring.

**4-E Floor Covering Installation:**

1. Vacuum the surface of the fiberboards to remove dust before laying the floor covering.
2. For best results install the floor covering within 48 hours of laying the fiberboards.
3. The floor covering is to be laid onto the surface of the fiberboards without exceeding the edges of the fiberboard.
4. Install flooring material as per flooring manufacturer's recommendations.

**4-F Final Wiring & Connections:** See section 1-E.

Diagram A - Lay Fiberboard in Diagonal 45° Pattern

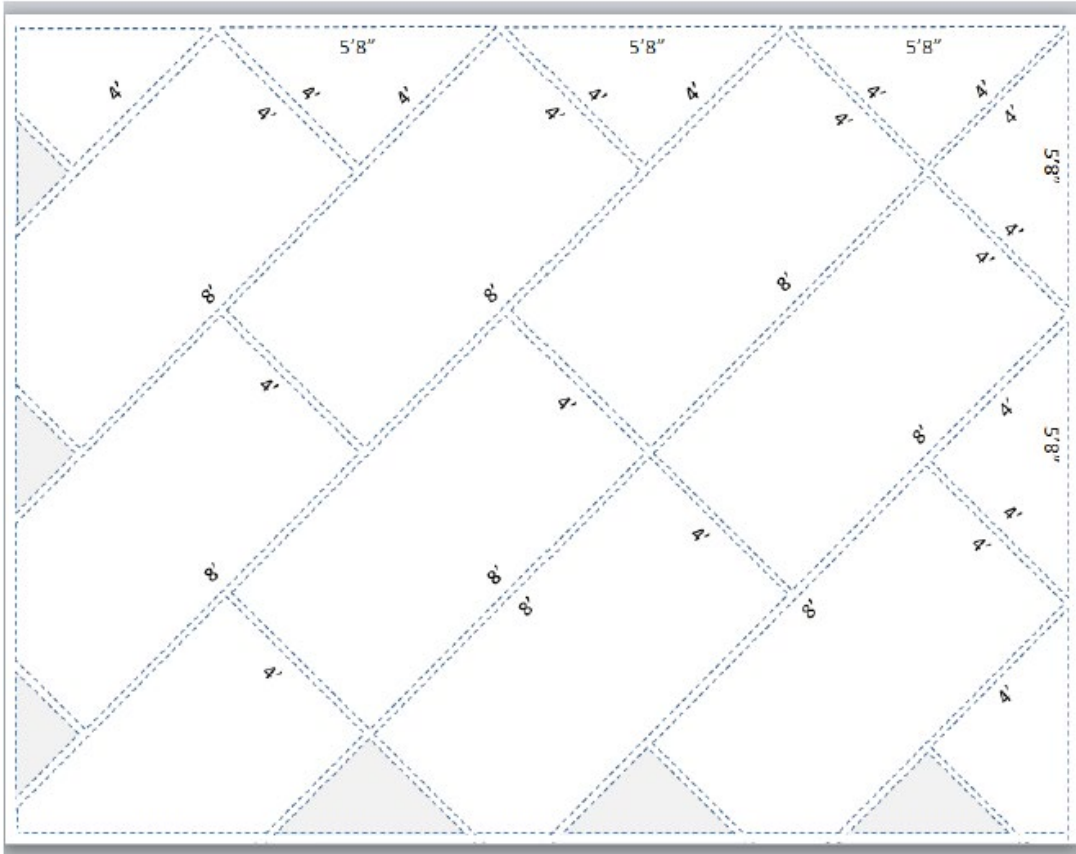

Fiberboard with Seams Taped



Layers

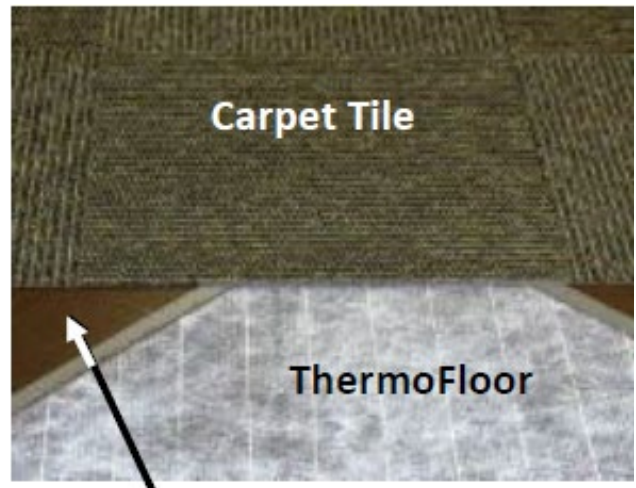

Fiberboard

## TROUBLESHOOTING

Steps for the **electrician** to trouble-shoot the radiant floor heating mats and **programmable** thermostat:

1. Turn power off at the main breaker. Check that the electrical connections are proper: 120V Power Lines connected to the 2 terminals marked LINE; heating mats connected to the 2 terminals marked LOAD (multiple mats connected in parallel: black-to-black and white-to-white); floor sensor connected to the 2 terminals marked Sensor.
2. Check to be sure all electrical connections are tight. An E2 error showing on the thermostat display screen indicates a loose sensor wire or a faulty sensor. Loose connections may also trip the GFCI.
3. Turn power on, use a Voltmeter to check the Line side of the thermostat to verify that the thermostat is receiving 120V power. If yes, proceed to Step 4. If not, trouble-shoot the power source.
4. Turn up the thermostat so that the thermostat calls for heat and the heat waves display on the thermostat display screen. If the waves appear, proceed to Step 5. If the waves do not appear, there may be a problem with the floor sensor. Check to make sure there is only one floor sensor connected to the thermostat. Connecting two sensors will prevent the thermostat from calling for heat. If two floor sensors were connected, turn off the power and disconnect one floor sensor. If only one sensor is connected, turn off the power, disconnect the sensor and measure the resistance of the floor sensor using an Ohmmeter. The resistance should be between 12 and 15 kOhms (12,000-15,000 Ohms) at 77°F to 68°F respectively. If not, call customer technical support.
5. With power on, use a voltmeter to determine if the load side of the thermostat registers 120V when the thermostat is calling for heat. If not, the thermostat may be faulty (it is not passing voltage to the mats). If the thermostat registers 120V on the load side, the thermostat is good. Proceed to Step 6 to check the heating mats.
6. Turn off power at the main breaker. Disconnect all wires and remove the thermostat. Check the resistance between each heating mat's white and black wires using an Ohmmeter. The resistance for each mat should be within 15% of the factory resistance recorded on the label R=N or as follows:

120V Mat 1.5' wide		120V Mat 3' wide		240V Mat 1.5' wide		240V Mat 3' wide	
Dimensions	Resistance Ohms	Dimensions	Resistance Ohms	Dimensions	Resistance Ohms	Dimensions	Resistance Ohms
1.5' x 4'	338±15%	3' x 2'	329±15%	1.5' x 8'	651±15%	3' x 4'	614±15%
1.5' x 5'	286±15%	3' x 3'	209±15%	1.5' x 10'	556±15%	3' x 5'	519±15%
1.5' x 6'	220±15%	3' x 4'	170±15%	1.5' x 11'	471±15%	3' x 6'	400±15%
1.5' x 8'	181±15%	3' x 5'	129±15%	1.5' x 12'	431±15%	3' x 8'	330±15%
1.5' x 10'	139±15%	3' x 6'	100±15%	1.5' x 14'	368±15%	3' x 10'	253±15%
1.5' x 12'	108±15%	3' x 8'	73±15%	1.5' x 16'	357±15%	3' x 12'	196±15%
		3' x 10'	64±15%	1.5' x 20'	274±15%	3' x 14'	167±15%
		3' x 12'	49±15%	1.5' x 24'	213±15%	3' x 16'	146±15%
						3' x 20'	125±15%
						3' x 24'	97±15%

If the mat resistance is not correct, call customer technical support. The mat heating wires may be damaged and may need to be repaired or the mat replaced.

7. To verify mats are working, with **power off**, connect the floor mats directly to power: 120V black-to-black (line); white-to-white (neutral); 240V black-to-black (line); red-to-red (line).
8. **Turn on power** to determine if the mats heat up. It may take 45 minutes or longer to feel the warm floor. Compare the warm floor to areas of the floor that are unheated to feel the difference.
9. If the mats heat up, **turn off the power** and replace the thermostat. If it is within the warranty period, return the thermostat for replacement.
10. If you do not determine the problem after performing the above steps, call customer technical support.

## ThermoFloor® RADIANT FLOOR HEATING UNDERLAYMENT 10-YEAR LIMITED WARRANTY

Thermosoft International Corporation (“Manufacturer”) warrants that its ThermoFloor® radiant floor heating underlayment (“Product”) for floating laminate flooring, floating wood flooring ceramic flooring and porcelain flooring (“Applicable Flooring”) is free from defects in manufacturing, materials and workmanship in manufacture and to perform under normal use for a period of 10 years from the date the Product was originally purchased (“Limited Warranty Period”). This warranty shall not be valid under the following conditions: 1) The preparation, conditions and installation of the Product is not in accordance with industry standards as outlined by the National Wood Flooring Association for wood floor applications, and the Tile Council of America for ceramic, porcelain and natural stone applications, The National Electric Code (NEC), the Canadian Electric Code (CEC) and all applicable local electrical and building codes; 2) the installation is not conducted as per Manufacturer’s written instructions; 3) the sub-floor is not within tolerances of vapor emissions per industry standards; 4) defective hardwood planks, tile, grout, or adhesive is used in the installation; 5) subfloor cracking, settling or displacement occurs; 6) there exists a failure of floor patching or leveling materials, or use of non-approved patching or leveling materials; or 7) improper installation materials or methods are used, 8) local overheating is caused by use not in accordance with Manufacturer’s instructions, 9) the Product is not connected to the power source by a licensed electrician, 10) the owner fails to retain and supply resistance measurements recorded during installation as specified by the Manufacturer’s instructions 11) the Product’s heating elements are cut, punctured or tampered with. This limited warranty is extended to the original property developer and/or the original occupant of the property where the Product is installed (the “Owner”) and does not cover damage to the Applicable Flooring. This Limited Warranty is further subject to the exclusions and limitations provided below and on the reverse side.

TO OBTAIN WARRANTY SERVICE, FOLLOW THE INSTRUCTIONS IN STEP 4 BELOW. UPON RECEIPT OF THE DEFECTIVE PRODUCT, PAPERWORK, RECEIPT AND RESISTANCE MEASURES, MANUFACTURER WILL EXAMINE AND TEST THE PRODUCT. IF IT IS DETERMINED THAT THE PRODUCT WAS PROPERLY INSTALLED AND FAILED DURING NORMAL USE AS A RESULT OF A MANUFACTURING, DEFECT, THE MANUFACTURER WILL REMEDY THE DEFECT OR FAILURE WITHOUT CHARGE TO THE CONSUMER PROVIDED MANUFACTURER RECEIVES NOTICE OF THE WARRANTY CLAIM IN THE MANNER PROVIDED BELOW WITHIN THE LIMITED WARRANTY PERIOD. THE REMEDY FOR ANY SUCH DEFECT IS LIMITED, AT MANUFACTURER’S OPTION, TO THE REPAIR, REPLACEMENT, OR REFUND OF THE PURCHASE PRICE OF THE PRODUCT. THE WARRANTY PERIOD FOR THE REPLACEMENT PRODUCT WILL EXPIRE 10 YEARS FROM THE DATE THAT THE ORIGINAL PRODUCT WAS PURCHASED.

THIS LIMITED WARRANTY DOES NOT APPLY TO THE THERMOSTATIC CONTROL UNIT WHICH IS A SEPARATELY PURCHASED COMPONENT THAT CARRIES ITS OWN WARRANTY.

MANUFACTURER WARRANTS THAT THE PRODUCT PRODUCES THE RATED WATT OUTPUT LISTED ON THE LABEL WHEN OPERATED AT THE RATED VOLTAGE. MANUFACTURER MAKES NO REPRESENTATION CONCERNING THE TEMPERATURE LEVEL THAT WILL BE PRODUCED BY THE PRODUCT.

MANUFACTURER ASSUMES NO LIABILITY FOR THE COST OF FLOOR COVERING MATERIALS OR THE COST TO REMOVE OR REPLACE THEM.

**IMPORTANT: FOR THIS WARRANTY TO BE VALID, THIS PRODUCT MUST BE CONNECTED TO A THERMOSTATIC CONTROL DEVICE WITH GROUND FAULT CIRCUIT INTERRUPTER (GFCI) BY A LICENSED ELECTRICIAN.**

THIS LIMITED WARRANTY IS FURTHER SUBJECT TO THE CONDITIONS, LIMITATIONS, AND EXCLUSIONS PROVIDED ON THE REVERSE SIDE.

## CONDITIONS/EXCLUSIONS TO THE LIMITED WARRANTY

THIS 10-YEAR LIMITED WARRANTY IS FURTHER MADE SUBJECT TO THE FOLLOWING CONDITIONS AND EXCLUSIONS, PLEASE READ THE FOLLOWING CAREFULLY:

1. Required Installation. To be covered by this Limited Warranty, the Product must be installed indoors following the Manufacturer's recommended installation instructions for the Product and the manufacturer's recommended installation instructions for the Applicable Flooring. This Product may only be used in "Type II" flooring applications, and is not suitable for areas exposed to constant moisture such as shower stalls, dairies, etc. This Product may not be used directly over expansion joints.
2. Limitation on Causes of Defects Covered Under Warranty. This limited warranty covers only defects in manufacturing materials or workmanship and does not cover defects, malfunctions or failures resulting from any other cause including, without limitation: (i) improper or inadequate installation; (ii) damage caused by trades people or visitors to the job site or by cutting or puncturing or other post installation damage to the heating elements; (iii) defects caused by fire, flood, tornado, hurricane, earthquake, acts of God, differential settlement, insect infestation, extraordinary environmental conditions, riot or other civil insurrections, or acts of war or conflict; (iii) defects caused by abusive conditions or accidents, such as but not limited to cutting, severe impact or abnormal vibrations; (iv) installation or use of the Product in any manner not recommended by the Manufacturer; and, (v) defects caused by improper or inadequate maintenance, cleaning, use or care of any Applicable Flooring installed over the Product, including without limitation, the use of improper or unrecommended cleaning solutions or cleaning practices.
3. Controlling Document. This warranty is the sole and exclusive description of warranties applicable to the Product. Any written or oral representation, warranties or guarantees concerning the Product which are inconsistent with or beyond the scope of the description contained herein are superseded by this document and deemed inapplicable or void.
4. Required Procedures to Submit a Warranty Claim. In order to obtain performance of any warranty obligation, the Owner must do the following:  
Contact the Manufacturer at the toll-free number listed below or by mail at the address listed below and request a claim form or visit [www.thermosoft.com/rma/](http://www.thermosoft.com/rma/) to download the form. Complete and return the claim form along with the defective Product, Product Label showing serial number, the original dated sales receipt and a copy of the resistance measures recorded during installation to the Manufacturer by certified mail return receipt requested within the Limited Warranty Period. The phone number and address to contact the Manufacturer for these purposes is as follows:

Thermosoft International Corporation  
Attention: Warranty Claim Department  
701 Corporate Woods Parkway  
Vernon Hills, IL 60061  
Phone: (847) 279-3800 Fax: (847) 279-8845

THIS LIMITED WARRANTY IS GIVEN IN LIEU OF IMPLIED WARRANTIES. IMPLIED WARRANTIES OF MERCHANTABILITY AND FITNESS FOR PARTICULAR PURPOSE ARE DISCLAIMED.

THIS WARRANTY GIVES YOU SPECIFIC LEGAL RIGHTS. YOU MAY ALSO HAVE OTHER RIGHTS THAT VARY FROM STATE TO STATE. TO THE EXTENT ALLOWED BY APPLICABLE LAWS, MANUFACTURER HEREBY DISCLAIMS ANY AND ALL SUCH RIGHTS.

UNDER NO CIRCUMSTANCES SHALL MANUFACTURER BE LIABLE TO THE OWNER, OR ANY OTHER PERSON FOR ANY CONSEQUENTIAL, INCIDENTAL, ECONOMIC, DIRECT, INDIRECT, GENERAL, OR SPECIAL DAMAGES ARISING OUT OF ANY BREACH OF WARRANTY, EXPRESS OR IMPLIED, UNDER THIS CONTRACT.

SOME STATES DO NOT ALLOW THE EXCLUSION OR LIMITATION OF INCIDENTAL OR CONSEQUENTIAL DAMAGES, SO THE ABOVE LIMITATION OR EXCLUSION MAY NOT APPLY TO YOU.

THIS LIMITED WARRANTY HEREBY SUPERSEDES ALL PRE-EXISTING WARRANTIES, EITHER EXPRESS OR IMPLIED, RELATING TO THE PRODUCT.